



DANGER



THIS TOOL FOR USE BY LICENSED OPERATORS ONLY.
READ AND OBEY ALL SAFETY AND OPERATING
INSTRUCTIONS BEFORE OPERATING TOOL.



R25 TOOL

OPERATOR'S SAFETY & OPERATING INSTRUCTION MANUAL



**SEMI-AUTOMATIC, LOW VELOCITY
PISTON TYPE FASTENING TOOL**



DANGER



THIS TOOL IS TO BE USED ONLY BY PROPERLY TRAINED AND LICENSED OPERATORS.

YOU MUST SUCCESSFULLY COMPLETE THE RAMSET TRAINING PROGRAM FOR THE TOOL AND OBTAIN A CERTIFIED OPERATOR'S LICENSE BEFORE HANDLING, LOADING OR OPERATING THIS TOOL.

ATTEMPTING TO HANDLE OR OPERATE THIS TOOL WITHOUT PROPER TRAINING AND LICENSING CAN RESULT IN SERIOUS INJURY TO THE OPERATOR OR BYSTANDERS.

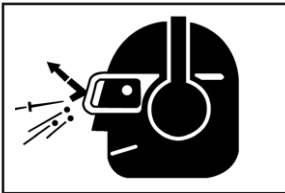

Operator's and bystanders must wear eye and hearing protection.

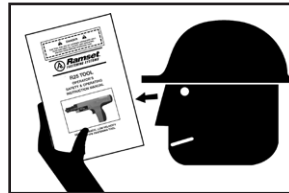

Read manual before operating tool.

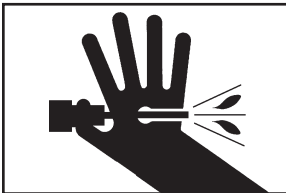

Never close tool with hand over fastener loading end of the tool. A serious hand injury from penetration by the piston or a discharged fastener could result.

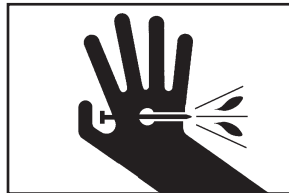

DANGER



Just as no one can merely read a book about driving an automobile and then hope to drive one safely, no one should attempt to use any Ramset tool without adequate, competent personal instruction. And just as one must be licensed to drive an automobile, one must also be licensed to use a powder actuated tool. No automobile instruction book or instructor can forewarn a learner against all possibilities and emergencies, nor can Ramset instructors and printed material detail all possible conditions surrounding the use of Ramset tools and products.

Responsibility for the safe and proper use of this tool rests with the tool user and the employer.

Preparation

Acceptable Base Materials

Powder actuated fastening is suitable for use in the following base materials only:

- Poured Concrete
- Structural Steel
- Masonry Joints (see page 8)

Never attempt to fasten into any other type of material. *Fastening into other materials can cause blindness or other serious injury.*

Unacceptable Base Materials

Never attempt to fasten into very hard or brittle materials such as cast iron, tile, glass, or rock of any type. *These materials can shatter, causing the fastener and/or base material fragments to fly free and cause serious injury to the tool operator and others.*

Never fasten into soft base materials, such as drywall or lumber products. *These materials may allow the fastener to travel completely through and out the other side, endangering those in the path of the fastener.*

Never fasten into any base material that does not pass the Center Punch test. *Failure to assure the suitability of the base material can result in serious injury to the eyes or other body parts.*

Center Punch Test

ALWAYS WEAR SAFETY GOGGLES WHEN PERFORMING THIS TEST.

1. Always check the material being fastened into for hardness before attempting any fastening operation.
2. Using a fastener as a center punch, strike the fastener against the work surface using an average hammer blow and check the results.

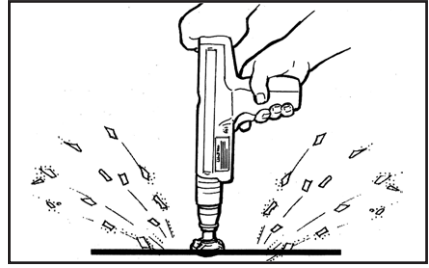

NEVER FASTEN INTO VERY HARD OR BRITTLE MATERIALS

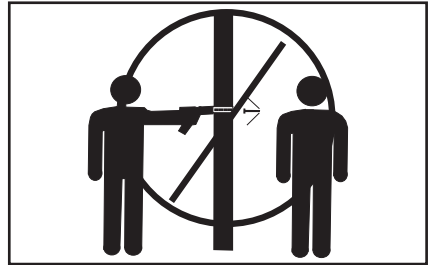

NEVER FASTEN INTO SOFT MATERIALS SUCH AS DRYWALL

Center Punch Test Results

1. If the fastener point is flattened, the material is too hard for a powder actuated fastening.
2. If the fastener penetrates the material easily, the material is too soft.
3. If the material cracks or shatters, the material is too brittle.
4. If the fastener makes a small indentation into the material, the material is suitable for fastening.

Loads & Load Selection Safety

1. Always make a test fastening after being sure that the base material is suitable for powder actuated fastening. Failure to determine the correct power level to be used may result in the use of excessive power, allowing the fastener to pass completely through the work material, causing serious or fatal injuries to others who may be in the path of the fastener.
2. Color-blind operators must always select loads by number to prevent use of an incorrect load for the same reasons as in #1 above.

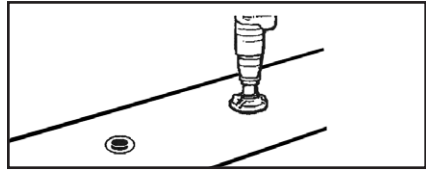

ALWAYS MAKE A TEST FASTENING

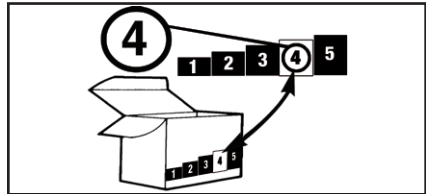

COLOR-BLIND OPERATORS MUST ALWAYS SELECT LOADS BY NUMBER

Workplace Safety

1. Operators and bystanders must always wear approved eye protection and approved hearing protection. Failure to do so may result in blindness or serious eye injury from flying debris and loss of hearing from constant or repeated unprotected exposure to fastening noise.
2. Always keep the work area clear of bystanders and unnecessary materials that could interfere with safe tool operation. Operating the tool in a congested or cluttered area may affect your ability to operate the tool safely.
3. Never operate tool if flammable or explosive materials are nearby. Powder loads burn and create sparks when fired and could ignite these materials or fumes.
4. Always post warning signs within 50 ft. of the area where fastening is to be done. Sign must state: "WARNING - Powder Actuated Tool In Use". Failure to warn others may result in serious injury to them. Contact Ramset at 1-800-348-3231 to obtain this sign.



KEEP WORK AREA CLEAR OF BYSTANDERS AND CLUTTER



NEVER OPERATE THE TOOL AROUND FLAMMABLE OR EXPLOSIVE MATERIALS



ALWAYS POST WARNING SIGNS

Tool Handling Safety

1. Always be sure tool is operating properly before attempting to use it. Follow the “Daily Function Check” shown to the right and described on page 9.
2. Always load tool using a strip load selected directly from a box indicating the power load type and number. Never attempt to use loose strip loads that could be mis-identified.
3. Never carry loose loads in pockets with pins or other hard objects.
4. Never load a tool unless you intend to immediately make a fastening. *Loading a tool and leaving it unattended in the work area can result in the tool being accidentally discharged by others.*
5. Never place your hand or any other body part over the fastener loading end of the tool. *Serious hand injury could result from being struck by either a fastener or the tool piston should the tool be accidentally fired.*
6. Always store the tool unloaded and keep the tool and the loads securely locked in a tool box. Keep keys away from children and unlicensed persons.
7. Always keep the tool pointed away from yourself and others.
8. Never carry a loaded tool around the work area.
9. Never allow anyone not trained to use the tool.
10. Never engage in horseplay with the tool.
11. Using the tool in poorly ventilated areas, cleaning tool or handling loads may result in exposure to lead or other substances known to cause birth defects, and other physical harm. Have adequate ventilation at all times and wash thoroughly after exposure.

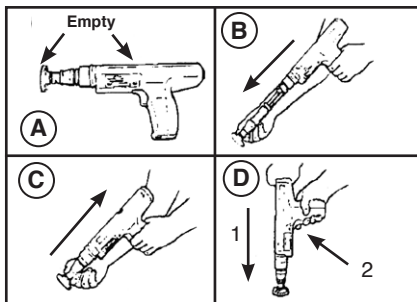

ALWAYS DO A DAILY FUNCTION CHECK BEFORE LOADING TOOL

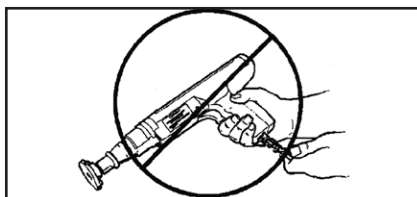

NEVER LOAD THE TOOL UNLESS IT IS TO BE USED IMMEDIATELY

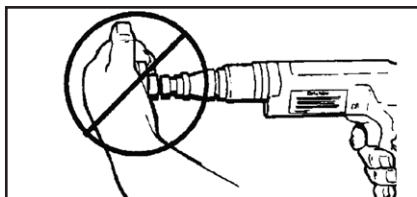

NEVER PLACE HANDS OR BODY OVER MUZZLE OPENING

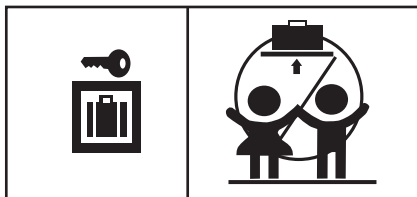

KEEP TOOL LOCKED & OUT OF THE REACH OF CHILDREN

FAILURE TO FOLLOW INSTRUCTIONS CAN CAUSE INJURY TO THE TOOL OPERATOR OR TO BYSTANDERS.

Fastener Driving Safety

1. Only use the tool for fastening into a suitable base material.
2. Never fire the tool without a fastener. *Firing a tool without a fastener will cause the piston to strike the work surface, and may cause serious injury to you and others in the work area.*
3. Always use the spall guard whenever possible to minimize flying particles or debris.
4. Always hold the tool perpendicular to and firmly against the work surface when making a fastening. *Failure to do so could allow a fastener to ricochet.*
5. Never attempt to drive a fastener close to an edge or to another fastener. *See page 8 for guidelines.*

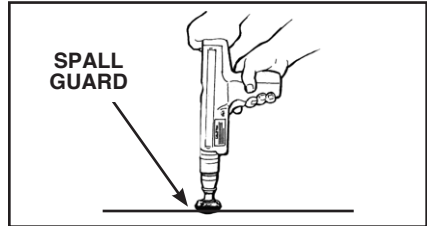

USE SPALL GUARD WHENEVER POSSIBLE

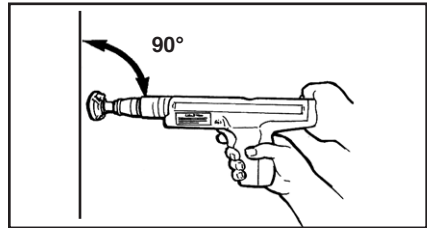

ALWAYS HOLD THE TOOL PERPENDICULAR TO THE WORK SURFACE

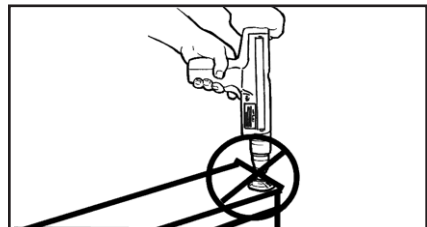

NEVER DRIVE A FASTENER CLOSE TO AN EDGE

ALWAYS FOLLOW THE MISFIRE PROCEDURE.

If the tool does not fire after the normal firing sequence, continue to hold the depressed tool against the work surface for at least 30 seconds. Then carefully lower the tool, remove the strip load, and put it in a can of water or other non-flammable liquid. Never carelessly discard a strip with live loads into a trash container.

If the tool becomes stuck or jammed with a live powder load, keep the tool pointed in a safe direction, and immediately tag it, "Danger- defective - do not use". Lock the tool in a tool box and call your local Ramset distributor for assistance.

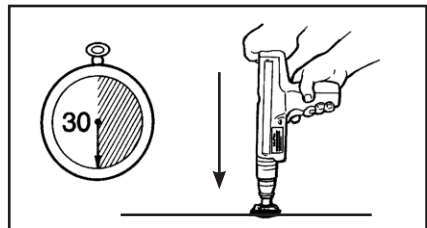

HOLD THE TOOL FIRMLY AGAINST THE WORK SURFACE FOR AT LEAST 30 SECONDS

FASTENERS / LOADS

Your Ramset R25 Tool uses only the Ramset fasteners and loads shown below or listed for the tool in the Product Catalog.



DANGER



Never use any other types of fasteners or strip loads in the Ramset R25 Tool. Use of other types of fasteners or loads may cause unintentional load discharge, damage the tool, cause poor fastening performance, or create a risk of serious injury to the operator or bystanders.

FASTENERS

.300 HEAD PLASTIC FLUTED DRIVE PINS

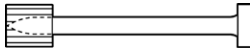

.145 Shank Diameter in Shank Lengths from 1/2" to 1-1/2"

.300 HEAD PLASTIC FLUTED DRIVE PINS WITH 7/8" WASHER

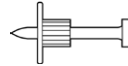

.145 Shank Diameter in Shank Lengths from 1" to 2"

1/4" - 20 THREADED STUDS



.145 Shank Diameter in Shank Lengths of 1/2" and 1" and Thread Lengths of 1/2", 3/4" and 1"

.300 HEAD POWER POINT PLASTIC FLUTED DRIVE PINS

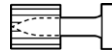

.150 Straight Shank in Shank Lengths from 1/2" to 7/8"
.150/.180 Step Shank in Lengths from 1" to 1-1/2"

8 mm HEAD TOP-HAT DRIVE PINS



.145 Shank Diameter in Shank Lengths from 1/2" to 1"

CEILING CLIP ASSEMBLIES



CONDUIT CLIP ASSEMBLIES



For 1/2" and 3/4" Diameter Conduit with 1" Premounted Fastener

Ceiling Clip with 1" or 1-1/4" premounted .145 Shank Pin and Ceiling Clip with 1" or 1-1/4" Premounted .150/.180 Shank Pin

LOADS

Ramset RS25 strip loads are specially made for use in the Ramset R25 Tool.



RS25 10 SHOT STRIP LOAD

The power level of the load is indicated by the number marked on each box, the color of the box, and the color on the tip of each load. As the number increases, the power level also increases.

Always perform the center punch test described on page 3 to test the base material.

Always make a test fastening using the lowest power level first. If more power is required to set the fastener, use the next higher power level until the powder level necessary to drive the fastener is reached.

POWER LEVEL	CATALOG NUMBER	LOAD COLOR	CASE COLOR
3	3RS25	Green	Brass
4	4RS25	Yellow	Brass
5	5RS25	Red	Brass

FASTENING APPLICATIONS

FASTENING APPLICATIONS

Your Ramset tool can be used for a wide range of fastening needs in a variety of base materials. Reading and follow these important fastening guidelines will help you get the best results from your tool, fasteners, and powder loads, as well as help you perform these fastening operations safely and effectively.

Powder actuated fastenings are permanent fastening so attempting to remove a fastener from concrete or steel may result in serious injury.

Fastening to Concrete

When fastening into concrete, always maintain a minimum spacing of 3" between fastenings and 3" from any free edge. Concrete thickness should be at least three times the intended penetration depth into the concrete. The primary exception to the 3" edge distance can occur in a sill plate application where, by necessity, the edge distance is reduced.

Driving fasteners too close to an edge or too close to each other can cause the concrete edge to fail or fasteners to fly free.

Fastening to Concrete Block or to Masonry Walls

While this application is not recommended, when used, it is necessary to take care to observe a 3" edge distance to avoid cracking the block and over penetration of the fastener to avoid loss of holding value. Fastening may be made into the horizontal joint but not into the vertical joint.

Fastening to Steel

Your Ramset tool can be used for fastening on the flat surfaces of structural steel. When fastening into steel, always maintain a minimum spacing of 1-1/2" between fastenings and 1/2" from any edge.

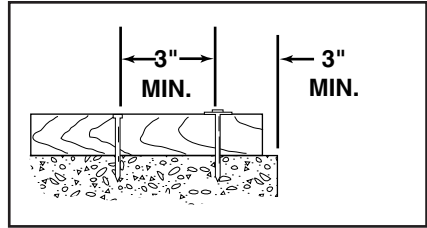

SPACING WOOD TO CONCRETE

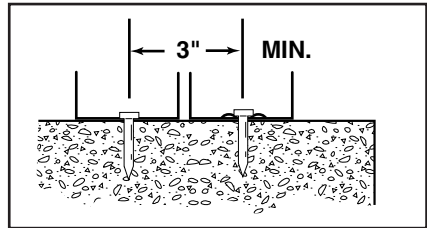

PENETRATION — THIN GAUGE METAL TO CONCRETE

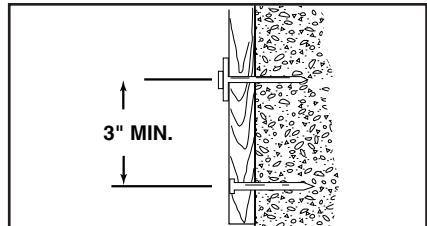

SPACING — FURRING STRIP TO CONCRETE

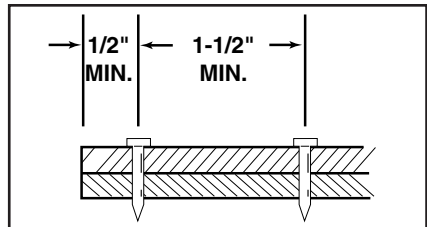

SPACING — STEEL TO STEEL

FASTENING APPLICATIONS

TOOL OPERATING INSTRUCTIONS

TOOL OPERATION

Daily Function Test

Always check the tool first to make sure that it does not contain a strip load or fastener. Test the tool several times by depressing the muzzle bushing fully on a hard surface and pulling the trigger. You should hear an audible click as the firing pin releases. Let up on the tool and check to be sure that the barrel has opened to the semi-open position.

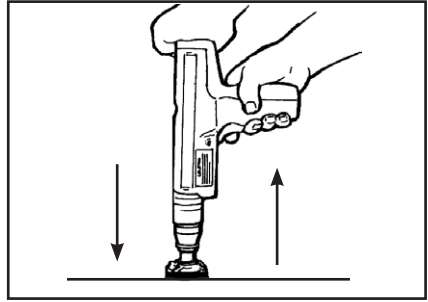

PERFORM THE FUNCTION TEST WITH EMPTY, UNLOADED TOOL

OPERATING THE RAMSET R25 TOOL

1. After checking to be sure that the tool is not loaded, point it in a safe direction and be sure that the barrel is fully extended and then close the tool to the semi-closed position. This assures that the piston is in position for the next fastening. Use the spall guard every time possible to minimize the risk of being struck by flying debris.

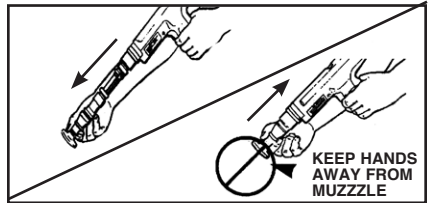

FULLY OPEN AND CLOSE TOOL TO THE SEMI-CLOSED POSITION

2. With finger off the trigger, place the fastener, point out, into the muzzle end of the tool until the point end is inside the muzzle. **NEVER** load a fastener with your finger on the trigger. **DO NOT** use excessive force when inserting a fastener. **STOP** immediately if excessive force is required, inspect the barrel to find out why the fastener is not entering the muzzle freely. **DO NOT** continue loading unless the problem is corrected.

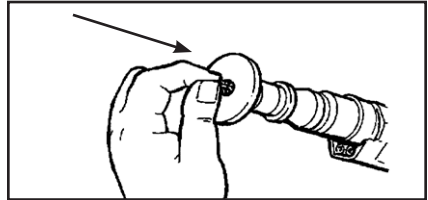

INSERT FASTENER INTO THE MUZZLE END OF THE TOOL WITH THE POINT OUT

3. With the tool pointed in a safe direction and finger away from the trigger, insert a load strip into the bottom of the handle and push it in until your finger is in firm contact with the handle recess.

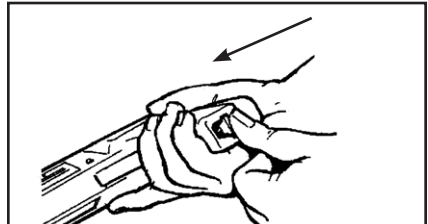

INSERT LOAD STRIP INTO THE OPENING IN THE BOTTOM OF THE HANDLE

TOOL OPERATING INSTRUCTIONS

4. Hold the tool perpendicular (90°) to the work surface with both hands and press firmly to fully depress the tool. Maintain firm downward pressure on the tool with both hands and pull the trigger to drive the fastener. **DO NOT DEPRESS THE TOOL AGAINST ANYTHING OTHER THAN THE INTENDED WORK SURFACE.** Holding the tool firmly in place will produce more consistent fastening quality and minimize tool wear or damage.

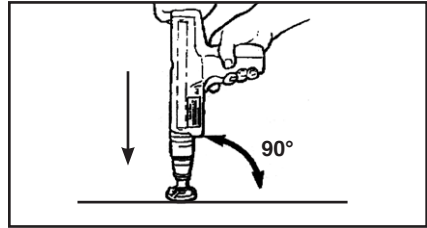

HOLD THE TOOL FIRMLY AND PERPENDICULAR TO THE WORK SURFACE

5. After making the fastening, fully open and then close the tool to the semi-closed position. This resets the piston and indexes a new load into place for the next fastening.
6. Insert another fastener in the muzzle end of the tool as before and the tool is ready for the next fastening. Keep your finger off of the trigger until the tool is in position to drive the fastener.

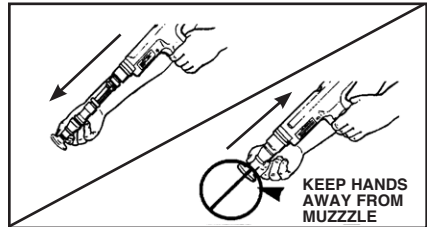

FULLY OPEN THE TOOL AND THEN CLOSE IT TO THE SEMI-CLOSED POSITION

7. To remove a used or partially used strip load from the tool, pull the strip out from the top of the tool. Do not try to remove the strip by pulling it out from the bottom of the handle. **NEVER** try to remove a jammed or stuck load strip. Should a "jammed" load strip occur, call your local Authorized Ramset Distributor for technical assistance.

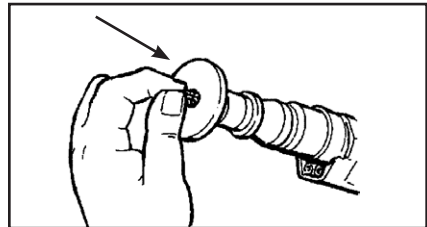

INSERT THE NEXT FASTENER

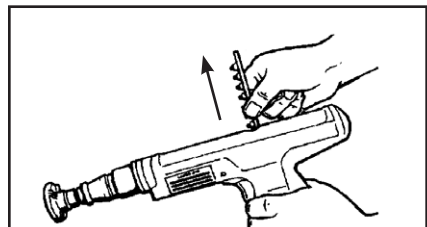

REMOVE THE LOAD STRIP ONLY FROM THE TOP OF THE TOOL

TOOL OPERATING INSTRUCTIONS

TROUBLESHOOTING

REFER TO PARTS SCHEMATIC FOR PROPER ASSEMBLY OF PARTS

– Overdriving of fasteners	– Excessive power	– Change to the next lower power level load strip color and number.
	– Soft base material	– Check base material (see page 3)
– Tool fails to fire	– Failure to depress completely	– See “Tool does not completely depress”
	– Excessive dirt buildup on breech face not allowing proper penetration of firing pin	– After following misfire procedure, check firing pin indentation on load. Clean breech face
	– Firing pin and/or breech damaged	– Replace damaged parts
– Tool does not completely depress	– Misassembled or damaged parts	– Check all parts in the receiver for damage or improper assembly.
– Reduction or loss of power	– Piston not being returned to the full rear position	– Barrel must be pulled completely open to properly position the piston.
	– Worn or damaged piston or piston ring	– Replace worn or damaged parts
	– Worn or broken pawls	– Replace pawls
– Tool cannot be cocked or opened	– Excessive dirt buildup	– Clean tool thoroughly
	– Damaged or bent piston	– Replace piston
	– Broken or damaged parts	– Tag tool with warning “Defective—Do Not Use” Place in a locked container and contact your local Ramset representative for service.
– Failure to index strip	– Strip not inserted in tool correctly or is damaged	– Check load strip. Properly dispose of damaged strip. (See page 6)
	– Damaged indexing mechanism	– Contact your Ramset Distributor for assistance
– Failure of tool to stay closed when pointed in the downward position	– Retaining ball missing	– Contact your Ramset Distributor for assistance

PARTS SCHEMATIC

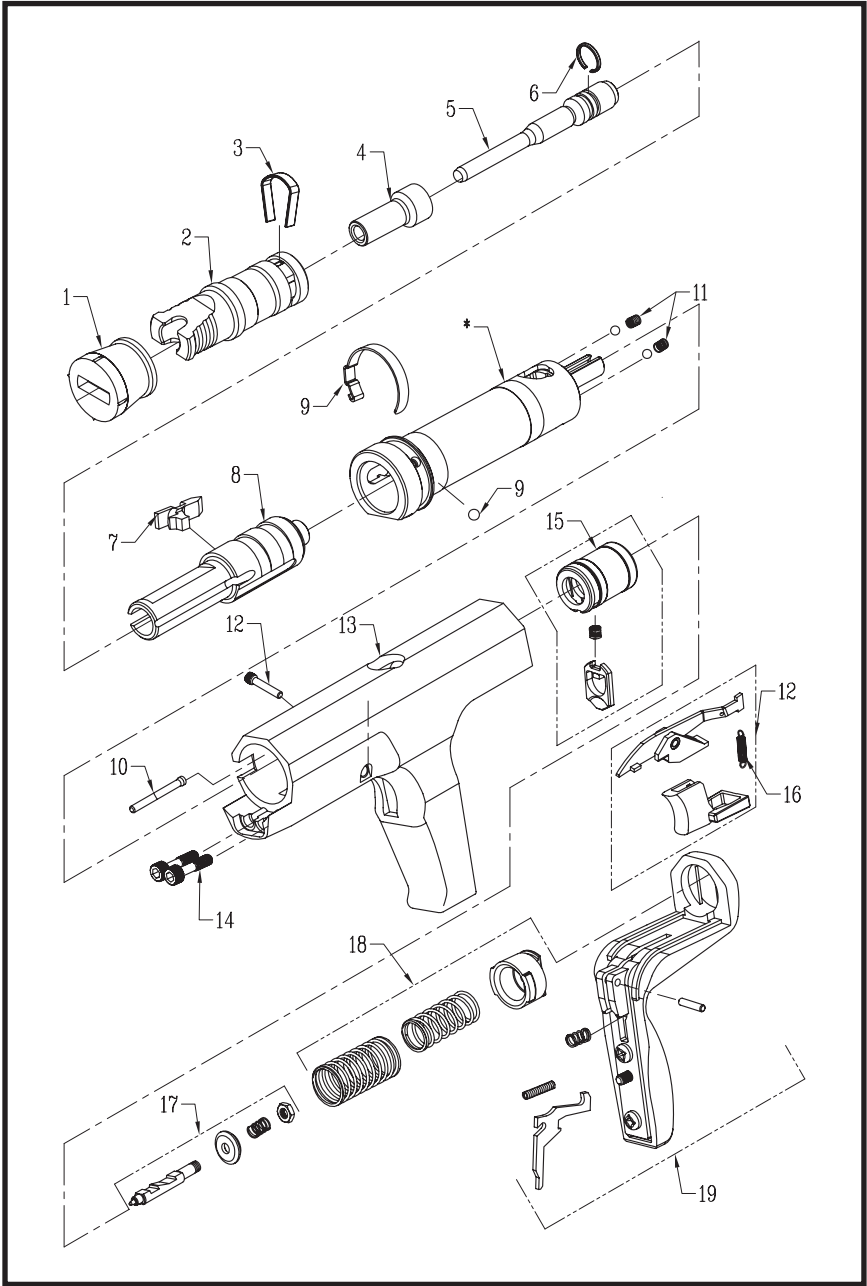

PARTS SCHEMATIC

12

PARTS LIST / MAINTENANCE

R25 TOOL PARTS LIST

KEY	PART NO.	DESCRIPTION
1	SC306053	SPALL GUARD
2	SC326009	FRONT BARREL (BASEPLATE)
3	SC301011A	SHEAR CLIP (PKG. OF 3)
4	SC306010	FASTENER GUIDE
5	SC325207A	PISTON ASSEMBLY
6	SC301208	PISTON RING
7	SC306012	PAWL (STOP)
8	SC305006	REAR BARREL (PISTON SLEEVE)
9	SC306014A	BARREL RETENTION ASSEMBLY
10	SC301016	PUSH PIN
11	SC301046A	DETENT BALL ASSEMBLY
12	SC301034A	TRIGGER ASSEMBLY AND PIN
13	SC325001A	TOOL BODY
14	SC306015	BOLT (2)
15	SC301300A	SEAR HOLDER ASSEMBLY
16	SC301531	SPRING, ADVANCE BAR
17	SC301400	FIRING PIN ASSEMBLY
18	SC301026A	FIRING PIN SPRING ASSEMBLY
19	SC301600	HANDLE ASSEMBLY

MAINTENANCE

**IMPROPERLY MAINTAINED TOOLS CAN CAUSE SERIOUS INJURIES
TO TOOL OPERATOR AND BYSTANDERS
CLEAN TOOL DAILY**

Always make sure the tool is not loaded before performing any service or repair and always wear safety goggles when cleaning or servicing the tool.

NORMAL CLEANING

All front end parts shown in the disassembly section are to be cleaned daily with a good detergent oil and wire brush. Remove all dirt and carbon buildup and wipe parts dry with a clean rag. Check all parts for wear or damage before reassembly and replace or repair any worn or damaged parts.

COMPLETE CLEANING / GENERAL MAINTENANCE

Heavy or constant exposure to dirt and debris may require that the tool be cleaned more extensively. Complete disassembly and cleaning of all parts may be necessary to restore the tool to normal operation. General maintenance should be performed every six months or more often if the tool is subjected to heavy use. Contact your authorized Ramset Distributor for assistance.

**ALWAYS FUNCTION TEST THE TOOL AFTER PERFORMING ANY
SERVICE. SEE PAGE 9 FOR DETAILS ON THE FUNCTION TEST.**

PARTS LIST / MAINTENANCE

DISASSEMBLY

TOOL DISASSEMBLY

1. Rotate the barrel retention clip off of the pawl using a flat blade screwdriver or the point of a long fastener.

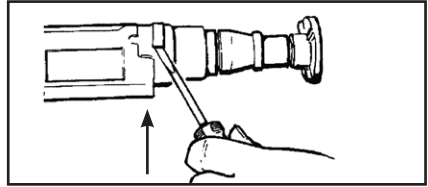

ROTATE THE BARREL RETENTION CLIP AWAY FROM PAWL

2. Remove the pawl by lifting it up and away from the tool body.

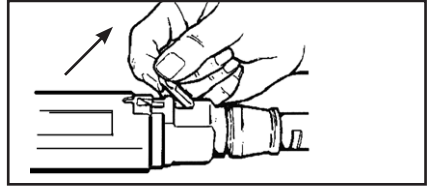

REMOVE THE PAWL

3. Slide the front barrel assembly out of the tool body.

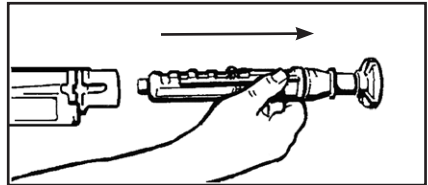

REMOVE THE BARREL ASSEMBLY

4. Unseat and remove the shear clip by prying it up with a flat blade screwdriver or fastener point. Remove the clip from the barrel by prying it up and away from the groove in the barrel. Use care to keep the clip from flying free when it is removed.

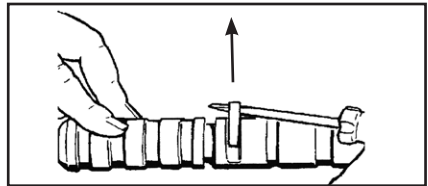

REMOVE THE SHEAR CLIP

5. Separate the front barrel and guide from the rear barrel assembly.

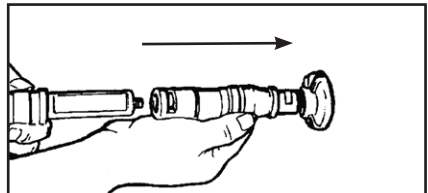

SEPARATE THE FRONT BARREL FROM THE REAR BARREL

DISASSEMBLY

- Slide the piston out of the rear barrel assembly and slide the guide out of the front barrel.

The tool is now disassembled for normal cleaning. Inspect all parts for wear or damage and clean or replace as required. Use detergent oil and cleaning brushes to remove dirt and powder residues. Wipe all parts dry before reassembly. **Wear safety goggles when cleaning tool parts.**

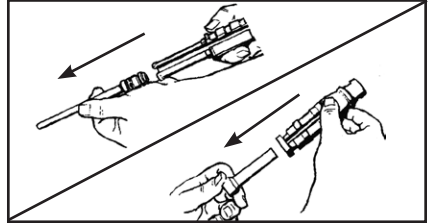

REMOVE THE PISTON AND FASTENER GUIDE

- Check the piston tip for damage and grind flat. The tip of the piston must be 90° to the shank. Grinding should only be done by qualified personnel. The minimum overall length of the piston must not be less than $4\text{-}5/8$ " long. When less than $4\text{-}5/8$ " long, the piston must be replaced to avoid tool damage.

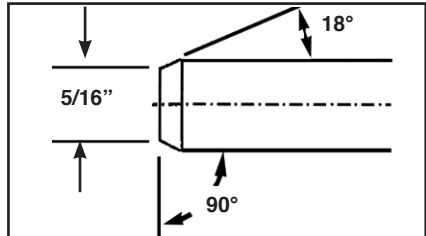

GRIND THE PISTON TIP FLAT AND BEVEL THE EDGE

- Reassemble the tool in the reverse order of disassembly. When sliding the front barrel onto the rear barrel, align the groove in the rear barrel with the groove in the front barrel.
- Align the groove in the rear barrel with the pawl opening in the tool body when placing the barrel assembly into the tool body. Replace the pawl and install the barrel retention clip.

ALWAYS PERFORM THE DAILY FUNCTION TEST BEFORE USING THE TOOL AFTER CLEANING OR SERVICING.

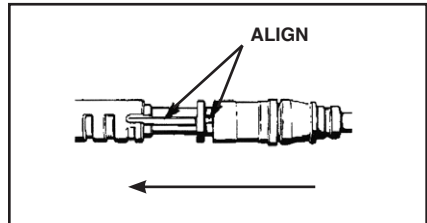

ALIGN THE FRONT AND REAR BARREL GROOVES

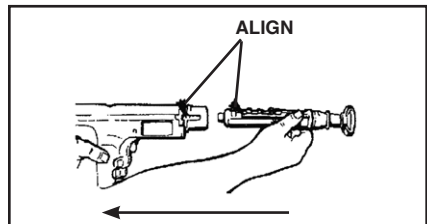

ALIGN THE BARREL ASSEMBLY GROOVE WITH THE PAWL OPENING

WARRANTY

ALL WARRANTIES OF THE PRODUCTS DESCRIBED HEREIN, EXPRESSED OR IMPLIED, INCLUDING THE WARRANTY OF MERCHANTABILITY AND FITNESS FOR PARTICULAR PURPOSES, ARE SPECIFICALLY EXCLUDED, EXCEPT FOR THE FOLLOWING: Ramset will repair or replace, at its sole option, any tool, part, or fastener which, within 1 year after sale by Ramset is found by Ramset to be defective in material or workmanship, normal wear and tear excluded. **THIS IS THE SOLE WARRANTY OF RAMSET AND THE SOLE REMEDY AVAILABLE TO THE BUYER AND IN NO EVENT WILL ANY DIRECT OR INDIRECT INCIDENTAL OR CONSEQUENTIAL DAMAGES, OR ANY OTHER DAMAGES, BE AVAILABLE.**

Copyright 2008 Ramset



**THE MODEL R25 TOOL COMPLIES WITH OSHA REQUIREMENTS
AND WITH ANSI A10.3 SPECIFICATIONS**

**FOR TOOL REPAIR SERVICE CONTACT YOUR LOCAL
AUTHORIZED RAMSET DISTRIBUTOR OR TO FIND
YOUR NEAREST RAMSET TOOL REPAIR CENTER
VISIT OUR WEB SITE AT WWW.RAMSET.COM
OR CALL 800-241-5640**



**Concrete Fastening Systems
Glendale Heights, IL 60139
800-RAMSET6 (1-800-726-7386)
www.ramset.com**

**Buy with Confidence...
Buy From Your Authorized Distributor**

AN ILLINOIS TOOL WORKS COMPANY
© ILLINOIS TOOL WORKS 2008