



Ramset[®]
DRIVING JOBSITE SPEED

Claim your free
sample, a poster,
or book a demo.



5/8" T4MAG DUAL SUBSTRATE PIN

TACKLE BOTH CONCRETE & STEEL



MADE IN
AMERICA

WWW.RAMSET.COM

WHY CHOOSE THE T4058SM?

Built for Productivity and Simplicity

Ramset® T4058SM Dual Substrate Pins are engineered to boost productivity on the jobsite. Designed to fasten interior track into both concrete and steel, this innovative 5/8" pin means you no longer have to alternate between 3/4" and 1/2" pins for different substrates.



Key Features

- **Dual Substrate Performance** - Use in both concrete and steel, eliminating the need for multiple pin sizes.
- **Time-Saving Efficiency** - Cuts downtime by avoiding pin changes — get more done, faster.
- **Simplified Jobsite Management** - Minimize the number of SKUs you need to track and carry.
- **Made in the USA** - BABA compliant.

T4MAG FUEL/PIN PACKS - 1000 PINS AND 2 FUEL CELLS PER BOX

Larger .125 shank diameter offers improved success rate (15 pin strip)

PART NUMBER	PIN LENGTH		DESCRIPTION
	IN.	(MM)	
T4012M	1/2	(12.7)	1/2" steel pin with T4 fuel cell
T4012SM	1/2	(12.7)	1/2" premium steel pin with T4 fuel cell
T4058SM	5/8	(16)	5/8" premium concrete and steel pin with T4 fuel cell
T4034BM	3/4	(19.1)	3/4" concrete pin with T4 fuel cell
T4034SM*	3/4	(19.1)	3/4" step shank pin with T4 fuel cell
T4100M	1	(25.4)	1" concrete pin with T4 fuel cell

Shank diameter = .125 *Shank diameter = .104 / .125 Head diameter = .250

Compatible with T4MAG gas tools. Sold in master cartons of 5000 minimum. Cartons cannot be split.

FASTENERS IN NORMAL WEIGHT CONCRETE

PART NUMBER SERIES	SHANK DIAMETER (INCH)	MINIMUM PENETRATION (INCH)	INSTALLED IN SOLID CONCRETE - CONCRETE COMPRESSIVE STRENGTH					
			ALLOWABLE LOAD - <i>Ultimate Load</i>					
			2000 PSI		4000 PSI		6000 PSI	
		TENSION (LBS)	SHEAR (LBS)	TENSION (LBS)	SHEAR (LBS)	TENSION (LBS)	SHEAR (LBS)	
T3/T4 STRAIGHT SHANK	0.125	5/8	83 <i>414</i>	109 <i>611</i>	78 <i>426</i>	80 <i>574</i>	95 <i>545</i>	128 <i>686</i>
		3/4	107 <i>541</i>	156 <i>855</i>	104 <i>593</i>	195 <i>977</i>	132 <i>658</i>	206 <i>1057</i>
T3034S/T4034SM STEP SHANK	0.104 / 0.125	5/8	-- --	-- --	102 <i>525</i>	138 <i>795</i>	101 <i>511</i>	119 <i>634</i>
T4058SM TAPERED SHANK	0.104 / 0.125	5/8	-- --	-- --	105 <i>587</i>	140 <i>857</i>	110 <i>573</i>	145 <i>958</i>

FASTENERS IN STEEL

PART NUMBER SERIES	SHANK DIAMETER (INCH)	TYPE OF SHANK	INSTALLED IN A36 STRUCTURAL STEEL - STEEL THICKNESS INCHES					
			ALLOWABLE LOAD - <i>Ultimate Load</i>					
			3/16 (.1875)		1/4 (.250)		3/8 (.375)	
		TENSION (LBS)	SHEAR (LBS)	TENSION (LBS)	SHEAR (LBS)	TENSION (LBS)	SHEAR (LBS)	
T3012 / T4012M	0.125	SMOOTH	63 <i>676</i>	162 <i>1356</i>	239 <i>1285</i>	211 <i>1417</i>	113 <i>914⁸</i>	197 <i>1327⁸</i>
T3012S / T4012SM	0.125	TAPER SMOOTH	183 <i>958</i>	332 <i>1660</i>	237 <i>1184</i>	356 <i>1782</i>	189 <i>943¹⁰</i>	392 <i>1960⁷</i>
T4058SM	0.125	TAPER SMOOTH	183 <i>958</i>	332 <i>1660</i>	237 <i>1184</i>	356 <i>1782</i>	189 <i>943¹⁰</i>	392 <i>1960⁷</i>
			INSTALLED IN ASTM A 572 GRADE 50 STEEL					
T3012 / T4012M	0.125	SMOOTH	103 <i>733</i>	222 <i>1682</i>	147 <i>950</i>	119 <i>973</i>	147 <i>856⁹</i>	112 <i>1014⁹</i>

Note 1: ALLOWABLE loads are shown in the LARGE BOLD font, *Ultimate* loads are shown in smaller italic font. **Note 2:** Testing conducted in accordance with ICC AC70 & ASTM E1190. **Note 3:** Safety factors are based on coefficient of variation. In accordance with ICC AC70, the safety factor will be no less than 5. **Note 4:** Cyclic, fatigue, shock loads and other design criteria may require a different safety factor. **Note 5:** Job site testing may be required to determine actual job site values. **Note 6:** Values shown are for fastenings that have the entire pointed end of the fastener driven through the steel plate; except as noted below. **Note 7:** Fastener penetration is .31" minimum. **Note 8:** Fastener penetration is .29" minimum. **Note 9:** Fastener penetration is .27" minimum. **Note 10:** Fastener penetration is .25" minimum. **Note 11:** For Sl: 1 lbf = 4.448 N, 1 inch = 25.4 mm, 1 ksi = 6.89MPa



155 Harlem Ave • Glenview, IL 60025
Phone: 800-848-5611

WWW.RAMSET.COM

rev.0226

SELECTION CHART



T4MAG FUEL/PIN PACK

1000 PINS AND 1 FUEL CELL PER BOX

Larger .125 shank diameter offers improved success rate (15 pin strip)



PART NUMBER	PIN LENGTH		DESCRIPTION
	IN	(MM)	
T4012M	1/2	(12.7)	1/2" steel pin with T4 fuel cell
T4012SM	1/2	(12.7)	1/2" premium steel pin with T4 fuel cell
T4058SM*	5/8	(16)	5/8" premium concrete and steel pin with T4 fuel cell
T4034BM	3/4	(19.1)	3/4" concrete pin with T4 fuel cell
T4034SM*	3/4	(19.1)	3/4" step shank pin with T4 fuel cell
T4100M	1	(25.4)	1" concrete pin with T4 fuel cell

Shank diameter = .125 *Shank diameter=.104/.125 Head diameter = .250

Compatible with T4MAG gas tools. Sold in master cartons of 5000 minimum. Cartons cannot be split.



T3MAG FUEL/PIN PACK

1000 PINS AND 1 FUEL CELL PER BOX

Larger .125 shank diameter offers improved success rate (15 pin strip)



PART NUMBER	PIN LENGTH		DESCRIPTION
	IN	(MM)	
T3012	1/2	(12.7)	1/2" steel pin with T3 fuel cell
T3012S	1/2	(12.7)	1/2" premium steel pin with T3 fuel cell
T3034B	3/4	(19.1)	3/4" concrete pin with T3 fuel cell
T3034S*	3/4	(19.1)	3/4" step shank pin with T3 fuel cell
T3100	1	(25.4)	1" concrete pin with T3 fuel cell

Shank diameter = .125 *Shank diameter=.104/.125 Head diameter = .250

Sold in master cartons of 5000 minimum. Cartons cannot be split.



GYPFAST / G2 FASTENERS

For attaching exterior sheathing, both gypsum and plywood, to metal studs

PART NO.	FASTENER DESCRIPTION 140" DIA. KNURLED SHANK 5/16" DIA. BUGLE HEAD	MASTER CARTON QUANTITY	MASTER CARTON WEIGHT	APPLICATIONS
GF112	1-1/2" (38mm)	6,000 nails/ctn (40- 150 ct. coils) 6 fuel cells	37 lbs.	Single Layer of Exterior Sheathing, Wood Furring and Blocking
GF212	2-1/2" (64mm)	2,700 nails/ctn (18 - 150 ct. coils) 3 fuel cells	26 lbs.	Multi-Layers of Sheathing, Wood Blocking, and Dimensional Lumber



LONG LIFE COATING ALLOWS FOR USE IN:

- Exterior applications
- Treated Lumber
- Treated Plywood
- Fire Resistant Plywood
- 20g to 14g applications

Ramset fasteners may be specified by their type or catalog number to satisfy fastening requirements.

PIN SPECIFICATIONS

- Made from AISI 1060-1065 steel. Austempered to a core hardness of 52-56 Rc
- Typical tensile strength: 270,000 psi
- Typical shear strength: 162,000 psi
- **STANDARD FINISHES**
Proprietary black
Mechanical zinc plate to a minimum thickness of .0002 meets requirements of ASTM B695—Class 5 Type I

APPROVALS/LISTINGS

- **ICC Evaluation Service, Inc.**
#ESR-2579 TrakFast Pins #ESR-1955 T3/T4 Fasteners
- **City of Los Angeles**
#RR-25264 TrakFast pins #RR-25739 T3/T4 pins

Collated Gas Fasteners in Concrete (TrakFast and T3/T4)

PART NUMBER SERIES	SHANK DIA (INCH)	MINIMUM PENETRATION (INCH)	INSTALLED IN SOLID CONCRETE CONCRETE COMPRESSIVE STRENGTH ALLOWABLE LOAD - <i>Ultimate Load</i>					
			2,000 PSI		3,000 PSI		4,000 PSI	
			TENSION (LBS)	SHEAR (LBS)	TENSION (LBS)	SHEAR (LBS)	TENSION (LBS)	SHEAR (LBS)
FPP - Straight Shank	0.109	5/8	60 <i>434</i>	55 <i>546</i>	55 <i>453</i>	75 <i>615</i>	55 <i>472</i>	95 <i>685</i>
		3/4	60 <i>595</i>	80 <i>650</i>	55 <i>583</i>	95 <i>699</i>	55 <i>571</i>	115 <i>749</i>
FPP - Step Shank	0.104/0.118	3/4	— —	— —	— —	— —	51 <i>256</i>	83 <i>418</i>

			2,000 PSI		4,000 PSI		6,000 PSI	
			TENSION (LBS)	SHEAR (LBS)	TENSION (LBS)	SHEAR (LBS)	TENSION (LBS)	SHEAR (LBS)
T3/T4 Straight Shank	0.125	5/8	83 <i>414</i>	109 <i>611</i>	78 <i>426</i>	80 <i>574</i>	95 <i>545</i>	128 <i>686</i>
		3/4	107 <i>541</i>	156 <i>855</i>	104 <i>593</i>	195 <i>977</i>	132 <i>658</i>	206 <i>1057</i>
T3/T4 Step Shank	0.104/0.125	5/8	— —	— —	102 <i>525</i>	138 <i>795</i>	101 <i>511</i>	119 <i>634</i>

PART NUMBER SERIES	SHANK DIA (INCH)	MINIMUM PENETRATION (INCH)	INSTALLED IN LIGHTWEIGHT CONCRETE / DECK / BLOCK ALLOWABLE LOAD - <i>Ultimate Load</i>					
			3,000 PSI LIGHT WEIGHT CONCRETE		3,000 PSI LIGHT WEIGHT CONCRETE WITH METAL DECK - LOWER FLUTE		HOLLOW CONCRETE MASONRY UNITS (CMU ANY LOCATION)	
			TENSION (LBS)	SHEAR (LBS)	TENSION (LBS)	SHEAR (LBS)	TENSION (LBS)	SHEAR (LBS)
FPP - Straight Shank	0.109	5/8	35 <i>234</i>	55 <i>403</i>	30 <i>239</i>	205 <i>1,025</i>	35 <i>347</i>	50 <i>435</i>
		3/4	80 <i>630</i>	100 <i>756</i>	40 <i>330</i>	235 <i>1,248</i>	— —	— —
FPP - Step Shank	0.104/0.118	3/4	— —	— —	— —	— —	36 <i>184</i>	58 <i>290</i>
T3/T4 Straight Shank	0.125	5/8	84 <i>418</i>	108 <i>540</i>	72 <i>361</i>	242 <i>1,210</i>	20 <i>243</i>	34 <i>264</i>
		3/4	108 <i>540</i>	173 <i>864</i>	93 <i>470</i>	288 <i>1,442</i>	— —	— —
T3/T4 Step Shank	0.104/0.125	5/8	109 <i>543</i>	181 <i>904</i>	95 <i>473</i>	219 <i>1,096</i>	71 <i>357</i>	123 <i>613</i>

Note 1: ALLOWABLE loads are shown in the **LARGE BOLD** font, *Ultimate* loads are shown in *smaller italic* font. **Note 2:** Testing conducted in accordance with ICC AC70 & ASTM E1190. **Note 3:** Safety factors are based on coefficient of variation. In accordance with ICC AC70, the safety factor will be no less than 5. **Note 4:** Values shown in concrete are for the fastener only. Connected members must be investigated separately. **Note 5:** Cyclic, fatigue, shock loads, and other design criteria may require a different safety factor. **Note 6:** Job site testing may be required to determine actual job site values. **Note 7:** Minimum edge distance in concrete is 3 inches unless otherwise approved. **Note 8:** For SI: 1 lbf = 4.448 N, 1 inch = 25.4 mm, 1 ksi = 6.89MPa. **Note 9:** T3/T4 straight shank allowable tension value in face shell of hollow CMU is 133 lbs.

Fastener Assemblies in Concrete

PART NUMBER SERIES	SHANK DIA. (INCH)	MINIMUM PENETRATION (INCH)	INSTALLED IN SOLID CONCRETE CONCRETE COMPRESSIVE STRENGTH ALLOWABLE LOAD - <i>Ultimate Load</i>						HOLLOW BLOCK Grade N, Type 1		
			4,000 PSI		6,000 PSI		3,000 PSI LIGHT WEIGHT LOWER FLUTE		FACE SHELL Min 1-1/4" face thickness		
			TENSION (LBS)	SHEAR (LBS)	TENSION (LBS)	SHEAR (LBS)	TENSION (LBS)	SHEAR (LBS)	TENSION (LBS)	SHEAR (LBS)	
GAS ASSEMBLIES	MP034TH*, M034* M100*, BR2*	5/8	78 426	80 574	95 545	128 686	72 361	242 1210	133 691	— —	
		3/4	104 593	195 977	132 658	206 1057	93 470	288 1442	84 444	84 446	
	M034BB	0.104/.118	5/8	51 256	83 418	— —	— —	— —	— —	36 184	58 290
	34 CLIP	0.104/.125	5/8	62 310	— —	106 528	— —	44 220	— —	— —	— —
	38HSMP034, 12HSMP034 34HSMP034, 10HSMP034 114HSMP034, 14TRHMP034 38TRHMP034, TSHMP034 12CCMP034L, 34CCMP034L	0.104/.125	5/8	60 357	117 587	107 533	191 957	54 269	230 1150	71 357	123 613
	T4058SM TAPERED SHANK	0.104/.125	5/8	105 587	140 857	110 573	145 958	— —	— —	— —	— —
POWDER ASSEMBLIES	M100BB, 38HSS10 12HSS10, 34HSS10 10HSS10, 14TRHSS10, 38TRHSS10	0.125/.150	3/4	107 559	213 1067	161 803	248 1240	96 478	231 1156	102 512	166 831

* ESR-1955 pin data applies. **Note 1:** ALLOWABLE loads are shown in the **LARGE BOLD** font, *Ultimate* loads are shown in *smaller italic* font. **Note 2:** Testing conducted in accordance with ICC AC70 & ASTM E1190 **Note 3:** Safety factors are based on coefficient of variation. In accordance with ICC AC70, the safety factor will be no less than 5. **Note 4:** Values shown in concrete are for fastener only. Connected members must be investigated separately. **Note 5:** Cyclic, fatigue, shock loads and other design criteria may require a different safety factor. **Note 6:** Job-site testing may be required to determine actual job site values. **Note 7:** Minimum edge distance is 3 inches unless otherwise approved. In hollow block applications, no more than one fastener per cell. **Note 8:** For Sl: 1 lbf = 4.448 N, 1 inch = 25.4 mm, 1 ksi = 6.89MPa. **Note 9:** 20 ga metal deck.

Gas Fasteners in Steel

PART NUMBER	SHANK DIA (INCH)	TYPE OF SHANK	INSTALLED IN A36 STRUCTURAL STEEL STEEL THICKNESS INCHES ALLOWABLE LOAD - <i>Ultimate Load</i>					
			3/16 (.1875)		1/4 (.250)		3/8 (.375)	
			TENSION (LBS)	SHEAR (LBS)	TENSION (LBS)	SHEAR (LBS)	TENSION (LBS)	SHEAR (LBS)
FPP012	0.109	SMOOTH	195 1047	292 1570	223 1220	278 1526	181 1048 ⁷	186 1076 ⁷
FPP012S	0.104/0.118	SMOOTH	— —	— —	148 744	157 787	166 832 ⁷	157 787 ⁷
T3012 /T4012	0.125	SMOOTH	63 676	162 1356	239 1285	211 1417	113 914 ⁸	197 1327 ⁸
T3012S /T4012S	0.125	TAPER SMOOTH	183 958	332 1660	237 1184	356 1782	189 943 ¹⁰	392 1960 ⁷
INSTALLED IN ASTM A 572 GRADE 50 STEEL								
T3012 /T4012	0.125	SMOOTH	103 733	222 1682	147 950	119 973	147 856 ⁹	112 1014 ⁹
T4058SM	0.125	TAPER SMOOTH	183 958	322 1660	237 1184	356 1782	189 943 ¹⁰	392 1960 ⁷

Note 1: ALLOWABLE loads are shown in the **LARGE BOLD** font, *Ultimate* loads are shown in *smaller italic* font. **Note 2:** Testing conducted in accordance with ICC AC70 & ASTM E1190. **Note 3:** Safety factors are based on coefficient of variation. In accordance with ICC AC70, the safety factor will be no less than 5. **Note 4:** Cyclic, fatigue, shock loads and other design criteria may require a different safety factor. **Note 5:** Job site testing may be required to determine actual job site values. **Note 6:** Values shown are for fastenings that have the entire pointed end of the fastener driven through the steel plate; except as noted below. **Note 7:** Fastener penetration is .31" minimum. **Note 8:** Fastener penetration is .29" minimum. **Note 9:** Fastener penetration is .27" minimum. **Note 10:** Fastener penetration is .25" minimum. **Note 11:** For Sl: 1 lbf = 4.448 N, 1 inch = 25.4 mm, 1 ksi = 6.89MPa

ICC-ES Evaluation Report

ESR-1955

Reissued August 2025

Revised December 2025

Subject to renewal August 2026

This report also contains:

- [City of LA Supplement](#)

- [CA Supplement w/ DSA and OSHPD](#)

ICC-ES Evaluation Reports are not to be construed as representing aesthetics or any other attributes not specifically addressed, nor are they to be construed as an endorsement of the subject of the report or a recommendation for its use. There is no warranty by ICC Evaluation Service, LLC, express or implied, as to any finding or other matter in this report, or as to any product covered by the report.

Copyright © 2025 ICC Evaluation Service, LLC. All rights reserved.

<p>DIVISION: 03 00 00— CONCRETE</p> <p>Section: 03 16 00— Concrete Anchors</p> <p>DIVISION: 04 00 00— MASONRY</p> <p>Section: 04 05 19.16— Masonry Anchors</p> <p>DIVISION: 05 00 00— METALS</p> <p>Section: 05 05 23—Metal Fastenings</p> <p>DIVISION: 09 00 00— FINISHES</p> <p>Section: 09 22 16.23— Fasteners</p>	<p>REPORT HOLDER:</p> <p>ITW RAMSET</p>	<p>EVALUATION SUBJECT:</p> <p>RAMSET T3/T4 POWER DRIVEN FASTENERS</p>	
---	---	---	---

1.0 EVALUATION SCOPE

Compliance with the following codes:

- 2024, 2021, 2018 and 2015 [International Building Code® \(IBC\)](#)
- 2024, 2021, 2018 and 2015 [International Residential Code® \(IRC\)](#)

Section number references in this report are for the 2024 IBC and IRC and the standards referenced therein. Corresponding section numbers for earlier code editions are shown in [Table 7](#) at the end of this report.

Property evaluated:

- Structural

2.0 USES

Ramset T3/T4 power-driven fasteners are power-actuated fasteners (PAFs) used to fasten building components such as light-gage cold-formed steel framing to normalweight concrete, sand-lightweight concrete, sand-lightweight concrete filled steel deck panels, concrete masonry units (CMUs) and structural steel substrate materials. The fasteners are used as alternatives to the cast-in-place concrete anchors described in IBC Section 1901.3 for placement in concrete; the embedded anchors described Section 8.1.4 of TMS 402, referenced in IBC Section 2107 for placement in masonry; and to the welds and bolts used to attach to steel, described in IBC Sections 2201.4. For structures regulated under the IRC, the fasteners may also be used where an engineered design is submitted in accordance with IRC Section R301.1.3.

The PAFs are intended for use in redundant applications, which are defined as applications where multiple PAFs support elements that are capable of redistributing the load to neighboring PAFs, in the event of a PAF failure. Examples include, but are not limited to, PAFs used to fasten cold-formed steel track, where the track can redistribute loads and PAF assemblies where the supported elements, such as conduit and ceiling framing can redistribute the loads to neighboring PAF assemblies.

3.0 DESCRIPTION

3.1 Ramset T3/T4 Power Driven Fasteners:

Ramset T3/T4 power-driven fasteners are manufactured from steel complying with ASTM A510, Grade 1060, and austempered to a Rockwell “C” 52 to 58 core hardness. See [Table 1](#) for shank descriptions, fastener dimensions, coating information and applicable base materials. See Figure 1 for fastener image examples.

3.2 Substrate Materials:

3.2.1 Concrete: Normalweight and lightweight concrete must comply with IBC Chapter 19 or IRC Section R402.2, as applicable. The minimum concrete compressive strength at the time of fastener installation must be as noted in the applicable allowable load table.

3.2.2 Steel Deck Panels: Steel deck panels must conform to a code-referenced material standard, with the minimum thickness, minimum yield strength and specified tensile strength noted in [Table 5](#). See Figures 2 and 3 for panel configuration requirements.

3.2.3 Concrete Masonry: CMUs must be minimum 8-inch-thick blocks, lightweight blocks conforming to ASTM C90. Mortar must be Type N or Type S in accordance with ASTM C270.

3.2.4 Structural Steel: Structural steel used in supports must comply with the minimum strength requirements of ASTM A36, ASTM A572 Grade 50 or ASTM A992, and must have thicknesses as noted in [Tables 6](#) and [7](#), as applicable.

4.0 DESIGN AND INSTALLATION

4.1 Design:

4.1.1 General: Design of the connection of the attached material to the base material must take into account the properties of the attached material and the need for redundancy, and must comply with the applicable requirements of the IBC.

Selection of fasteners must take into consideration the applicable base material and the length of the fastener. The minimum fastener length must be determined as follows:

- Unless otherwise noted, for installation into concrete, concrete-filled steel deck panels, concrete masonry and steel base materials, the minimum effective shank length shown in [Table 1](#) must equal or exceed the sum of the thickness of the attached material and the minimum embedment depth (penetration) shown in the applicable tables in this report.
- For installation through steel base materials, the minimum effective shank length shown in [Table 1](#) must equal or exceed the sum of the following: the thickness of the attached material, the thickness of the base material and the required point penetration shown in the applicable tables in this report.

4.1.2 Allowable Loads: The applicable allowable shear and tension load tables for the fasteners driven into different base materials may be determined by referencing [Table 1](#).

The most critical applied loads, excluding seismic load effects, resulting from the load combinations in Section 2.4 of ASCE 7 (referenced in IBC Section 1605.1) or IBC Section 1605.2 must not exceed the allowable loads described in this section. For fasteners which are subjected to seismic loads, see Section 4.1.6 for additional information.

The allowable shear and tension (pullout) values in the tables of this report are for use in allowable stress design (ASD). The allowable loads apply to the interaction between the fasteners and the specified base materials only, and limit states such as pull-over and lateral bearing, which are governed by the properties of attached materials, are outside the scope of this report. Design of the connection to the attached material must comply with the applicable requirements of the IBC. The stress increases and load reductions described in IBC Section 1605.2 are not allowed.

4.1.3 Combined Loading: For fasteners subjected to both shear and tension loads, compliance with the following interaction equation must be verified:

$$(p/P_a) + (v/V_a) \leq 1$$

where:

- p = Actual applied tension load on fastener, lbf(N)
- P_a = Allowable tension load for the fastener, lbf (N)
- v = Actual applied shear load on fastener, lbf (N)
- V_a = Allowable shear load for the fastener, lbf (N)

4.1.4 Steel-to-steel Connections: When the fasteners listed in [Tables 6](#) and [7](#) are used in connections of two steel elements in accordance with Section J5 of AISI S100, connection capacity must be determined in accordance with Sections 4.1.4.1 and 4.1.4.2, as applicable.

4.1.5 Connection Strength - Tension: To determine tensile connection strength in accordance with Section J5.2 of AISI S100, the fastener tension strength, pull-out strength and pull-over strength must be known. These characteristics must be determined as follows:

- **PAF Tensile Strength:** The allowable fastener tension strengths must be calculated in accordance with Section J5.2.1 of AISI S100 using a value of 260,000 psi for F_{uh}.
- **Pull-out Strength:** See [Tables 6](#) or [7](#), as applicable, for available pull-out strength.
- **Pull-over Strength:** The available pull-over strengths must be calculated in accordance with Section J5.2.3 of AISI S100.

4.1.5.1 Connection Strength - Shear: To determine shear connection strength in accordance with Section J5.3 of AISI S100, the fastener shear strength, bearing and tilting strength, pull-out strength in shear, net section rupture strength and shear strength limited by edge distance must be known. These characteristics must be determined as follows:

- **PAF Shear Strength:** The allowable fastener shear strengths must be calculated in accordance with Section J5.3.1 of AISI S100 using a value of 260,000 psi for F_{uh}.
- **Bearing and Tilting Strength:** The available bearing and tilting strengths must be calculated in accordance with Section J5.3.2 of AISI S100.
- **Pull-out Strength in Shear:** The available pull-out strength in shear must be the applicable allowable shear strength from [Table 6](#) or [7](#), as applicable, or must be calculated in accordance with Section J5.3.3 of AISI S100.
- **Net Section Rupture Strength and Shear Strength Limited by Edge Distance:** The net section rupture strength must be determined in accordance with Section J5.3.4 of AISI S100 and the shear strength limited by edge distance must be determined in accordance with Section J5.3.5 of AISI S100.

4.1.6 Seismic Considerations: The fasteners may be used when subjected to seismic loads as follows:

1. The fasteners may be used for attachment of nonstructural components listed in Table 13.1-1 of ASCE 7, which are exempt from the requirements of ASCE 7.
2. Concrete Base Materials: The fasteners installed in concrete base materials may be used to support acoustical tile or lay-in panel suspended ceiling systems, distributed systems and distribution systems where the service load on any individual fastener does not exceed the lesser of 90 lbf (400 N) or the published allowable load shown in [Tables 2](#), [3](#) and [5](#), as applicable.
3. Steel Base Materials: The fasteners installed in steel may be used for attaching nonstructural components where the service load on any individual fastener does not exceed the lesser of 250 lbf (1112 N) or the published allowable load shown in [Tables 6](#) and [7](#), as applicable.
4. Interior, Nonstructural Walls: For interior, nonstructural walls that are not subject to sustained tension loads and are not a bracing application, the power-driven fasteners described in Section 3.0 may be used to attach steel track to concrete or steel in all Seismic Design Categories. In Seismic Design Categories D, E and F, the allowable shear load due to transverse pressure must be no more than 90 pounds (400 N) when attaching to concrete; or 250 pounds (1,112 N) when attaching to steel. Substantiating calculations are submitted addressing the fastener-to-base-material capacity and the fastener-to-attached-material capacity. Interior nonstructural walls are limited to locations where bearing walls, shear walls or braced walls are not required by the approved plans. The design load on the fastener must not exceed the allowable load shown in [Tables 2](#), [3](#), [5](#), [6](#) and [7](#), as applicable.

4.2 Installation:

4.2.1 General: The fasteners must be installed in accordance with this report and the ITW Ramset published installation instructions. A copy of these instructions must be available on the jobsite at all times during installation.

The fasteners are installed with a power fastening tool in accordance with ITW Ramset recommendations. The fastener penetration, spacing and edge distances must be as noted in the tables of this report. For fasteners installed into concrete, the fasteners must not be driven until the concrete has reached the designated compressive strength.

5.0 CONDITIONS OF USE:

The ITW Ramset T3/T4 power driven fasteners described in this report comply with, or are suitable alternatives to what is specified in, those codes listed in section 1.0 of this report, subject to the following conditions:

- 5.1 The fasteners must be manufactured and identified in accordance with this report.
- 5.2 Fastener installation must comply with this report and ITW Ramset published installation instructions. In the event of a conflict between this report and the ITW Ramset published installation instructions, this report governs.
- 5.3 Calculations demonstrating that the applied loads are less than the allowable loads described in this report must be submitted to the code official. The calculations must be prepared by a registered design professional where required by the statutes of the jurisdiction in which the project is to be constructed.
- 5.4 Refer to Section 4.1.6 for seismic considerations.
- 5.5 The minimum concrete thickness must be three times the fastener embedment, except where noted otherwise in this report.
- 5.6 The use of fasteners is limited to uncracked concrete or masonry. Cracking occurs when $f_t > f_r$ due to service loads or deformations.
- 5.7 Installation must be limited to dry interior environments, which include exterior walls which are protected by an exterior wall envelope.
- 5.8 The use of fasteners in contact with preservative-treated or fire-retardant-treated wood is outside the scope of this report.
- 5.9 The fasteners are manufactured under a quality control program with inspections by ICC-ES.

6.0 EVIDENCE SUBMITTED

Data in accordance with the [ICC-ES Acceptance Criteria for Power-actuated Fasteners Driven into Concrete, Steel, and Masonry Elements \(AC70\(24\)\)](#), dated April 2025.

7.0 IDENTIFICATION

- 7.1 The ICC-ES mark of conformity, electronic labeling, or the evaluation report number (ICC-ES ESR-1955) along with the name, registered trademark, or registered logo of the report holder must be included in the product label.
- 7.2 In addition, the containers of the ITW Ramset T3/T4 power driven fasteners must be labeled with the manufacturer's name (ITW Ramset); the product name, length catalog number, and quantity; and the manufacturing date. In addition, all the fasteners must be identified by the letter "R" stamped into the fastener head.
- 7.3 The report holder contact information is the following:

ITW RAMSET
155 HARLEM AVENUE
GLENVIEW, ILLINOIS 60025
(800) 848-5611
www.ramset.com
Mechanical-Anchors@itwccna.com

TABLE 1—RAMSET T3/T4 FASTENERS

FASTENER ¹	SHANK TYPE	SHANK DIAMETER (inch)	HEAD DIAMETER (inch)	MAXIMUM POINT LENGTH (inch)	MINIMUM EFFECTIVE SHANK LENGTH (inch)	FASTENER COATING	APPLICABLE BASE MATERIAL	APPLICABLE LOAD TABLES
T3### T4###	Smooth, straight	0.125	0.253	0.230	Designated shank length	Black oxide, Zinc	Concrete	2 , 3 , 5
							Masonry	4
							Steel	6 , 7
T3034S T4034S	Smooth, stepped	0.104/0.125	0.253	n/a	0.725	Zinc	Concrete	2 , 3 , 5
T4058S	Tapered shank	0.129	0.250	0.353	0.682	Zinc	Concrete	2

For **SI**: 1 inch = 25.4 mm.

¹### denotes numbers used in fastener designation.

TABLE 2—ALLOWABLE TENSION AND SHEAR VALUES FOR T3/T4 FASTENERS INSTALLED IN NORMAL-WEIGHT CONCRETE (lbf)

SHANK TYPE	NOMINAL SHANK DIAMETER (inch)	MINIMUM EDGE DISTANCE (inches)	MINIMUM SPACING (inches)	MINIMUM EMBEDMENT DEPTH (inch)	ALLOWABLE LOADS (lbf)					
					2,500 psi		4,000 psi		6,000 psi	
Concrete Compressive Strength:					Tension	Shear	Tension	Shear	Tension	Shear
Load Direction:										
Straight	0.125	3.2	4.0	⁵ / ₈ ³ / ₄	83 107	109 156	78 104	80 195	95 —	128 —
Stepped	0.104/0.125	3.0	4.0	⁵ / ₈	—	—	102	138	101	119
Tapered	0.129	3.5	4.0	⁵ / ₈	—	—	105	140	110	145

For **SI**: 1 inch = 25.4 mm, 1 psi = 6.89 kPa, 1 lbf = 4.45 N.

¹The fasteners must not be driven until the concrete has reached the designated minimum compressive strength. Minimum concrete thickness is three times the fastener embedment into the concrete.

TABLE 3—ALLOWABLE TENSION AND SHEAR VALUES FOR T3/T4 FASTENERS INSTALLED IN MINIMUM 3,000 psi SAND-LIGHTWEIGHT CONCRETE (lbf)

SHANK TYPE	NOMINAL SHANK DIAMETER (inch)	MINIMUM SPACING (inches)	MINIMUM EDGE DISTANCE (inches)	MINIMUM EMBEDMENT DEPTH (inch)	ALLOWABLE LOADS (lbf)	
					Tension	Shear
Straight	0.125	4.0	3.2	⁵ / ₈ ³ / ₄	84	108
					108	173
Stepped	0.104/0.125	4.0	3.0	⁵ / ₈	109	181

For **SI**: 1 inch = 25.4 mm, 1 psi = 6.89 kPa, 1 lbf = 4.45 N.

¹The fasteners must not be driven until the concrete has reached the designated minimum compressive strength. Minimum concrete thickness is three times the fastener embedment into the concrete, unless noted otherwise.

TABLE 4—ALLOWABLE TENSION AND SHEAR VALUES FOR T3/T4 FASTENERS INSTALLED IN HOLLOW CONCRETE MASONRY UNITS (CMUs)^{1,2} (lbf)

SHANK TYPE	NOMINAL SHANK DIAMETER (inch)	MINIMUM EDGE DISTANCE (inches)	MINIMUM SPACING (inches)	MINIMUM EMBEDMENT DEPTH (inch)	ALLOWABLE LOADS (lbf)					
					Fastener Location:		Face Shell ¹		Horizontal Mortar Joint (Bed Joint) ²	
Load Direction:					Tension	Shear	Tension		Shear ³	
							Type N ⁴	Type S ⁵	Type N ⁴	Type S ⁵
Straight	0.125	2	4	5/8	133	—	14	21	22	33

For SI: 1 inch = 25.4 mm, 1 lbf = 4.45 N.

¹Fasteners must be located a minimum of 2 inches from the mortar joints, center web and end web of the CMU.

²Fasteners must not be installed in the head joints. Fasteners installed in the bed joint must be installed a minimum of 8 inches from the end of the wall. Multiple fasteners in a bed joint must be spaced a minimum of 8 inches.

³Value applies to loads both parallel and perpendicular to the bed joint.

⁴Value applies to fasteners installed into Type N mortar.

⁵Value applies to fasteners installed into Type S mortar.

TABLE 5—ALLOWABLE TENSION AND SHEAR VALUES FOR FASTENERS INSTALLED THROUGH METAL DECK INTO MINIMUM 3000 psi SAND-LIGHTWEIGHT CONCRETE¹

SHANK TYPE	NOMINAL SHANK DIAMETER (inch)	MINIMUM SPACING (inches)	MINIMUM EMBEDMENT DEPTH (inch)	ALLOWABLE LOADS (lbf)							
				Deck Type:				1 1/2-inch deep "B" type steel deck ³			
Fastener Location:				3-inch deep "W3" type steel deck ²		1 1/2-inch deep "B" type steel deck ³		Upper flute		Lower flute	
Load Direction:				Tension	Shear	Tension	Shear	Tension	Shear	Tension	Shear
Straight	0.125	4.0	5/8	—	—	72	242	—	—	—	—
			3/4	—	—	93	288	—	—	—	—
Stepped	0.104/0.125	4.0	5/8	103	221	95	219	101	215	107	224

For SI: 1 inch = 25.4 mm, 1 psi = 6.89 kPa, 1 lbf = 4.45 N.

¹The fasteners must not be driven until the concrete has reached the designated minimum compressive strength. Minimum concrete thickness is three times the fastener embedment into the concrete.

²The steel deck must have a minimum base-metal thickness of 0.035 inch, a minimum yield strength of 38 ksi, and a minimum tensile strength of 52 ksi. Fasteners installed through the lower flutes of the deck must have a minimum edge distance of 1 1/8 inches from the edge of the steel deck and 3 inches from the end of the deck. Concrete thickness above the deck must be a minimum of 3 1/2 inches. See Figure 3 of this report.

³The steel deck must have a minimum base-metal thickness of 0.035 inch, a minimum yield strength of 38 ksi, and a minimum tensile strength of 52 ksi. Fasteners installed through the lower flutes of the deck must have a minimum edge distance of 7/8 inches from the edge of the steel deck and 3 inches from the end of the deck. Concrete thickness above the deck must be a minimum of 2 1/4 inches. See Figure 2 of this report.

TABLE 6—ALLOWABLE TENSION AND SHEAR VALUES FOR T3/T4 FASTENERS INSTALLED IN ASTM A36 STEEL¹ (lbf)

NOMINAL SHANK DIAMETER (inch)	MINIMUM EDGE DISTANCE (inch)	MINIMUM SPACING (inch)	STEEL THICKNESS (inch)					
			3/16		1/4		3/8 ²	
			Tension ³	Shear	Tension ³	Shear	Tension	Shear
0.125	0.5	1.0	63	162	239	211	113	197

For SI: 1 inch = 25.4 mm, 1 lbf = 4.45 N.

¹The allowable tension and shear values are for fastenings that have the point end of the fastener driven through the steel base material, unless otherwise noted.

²Fastener penetration in 3/8 inch steel is a minimum of 0.29 inch.

³For steel-to-steel connections designed in accordance with Section 4.1.4, the tabulated allowable load may be increased by a factor of 1.25, and the design strength may be taken as the tabulated allowable load multiplied by a factor of 2.0.

**TABLE 7—ALLOWABLE TENSION AND SHEAR VALUES FOR T3/T4 FASTENERS
INSTALLED IN ASTM A572 GRADE 50 OR ASTM A992 STEEL¹ (lbf)**

NOMINAL SHANK DIAMETER (inch)	MINIMUM EDGE DISTANCE (inch)	MINIMUM SPACING (inch)	STEEL THICKNESS (inch)					
			³ / ₁₆		¹ / ₄		³ / ₈ ²	
			Tension ³	Shear	Tension ³	Shear	Tension	Shear
0.125	0.5	1.0	103	222	147	119	147	112

For SI: 1 inch = 25.4 mm, 1 lbf = 4.45 N.

¹The allowable tension and shear values are for fastenings that have the pointed end of the fastener driven through the steel base material, unless otherwise noted.

²Fastener penetration in ³/₈ inch steel is a minimum of 0.27 inch.

³For steel-to-steel connections designed in accordance with Section 4.1.4, the tabulated allowable load may be increased by a factor of 1.25, and the design strength may be taken as the tabulated allowable load multiplied by a factor of 2.0.



From left to right: T3034B/T4034B, T3100/T4100 and T3034S/T4034S.

FIGURE 1—RAMSET T3/T4 FASTENERS

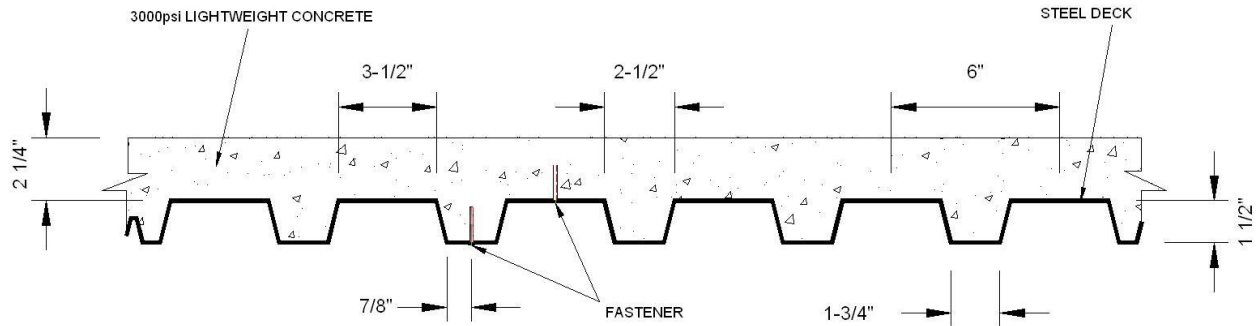

FIGURE 2—FASTENER INSTALLATION SAND-LIGHTWEIGHT CONCRETE FILLED “B” STEEL DECK

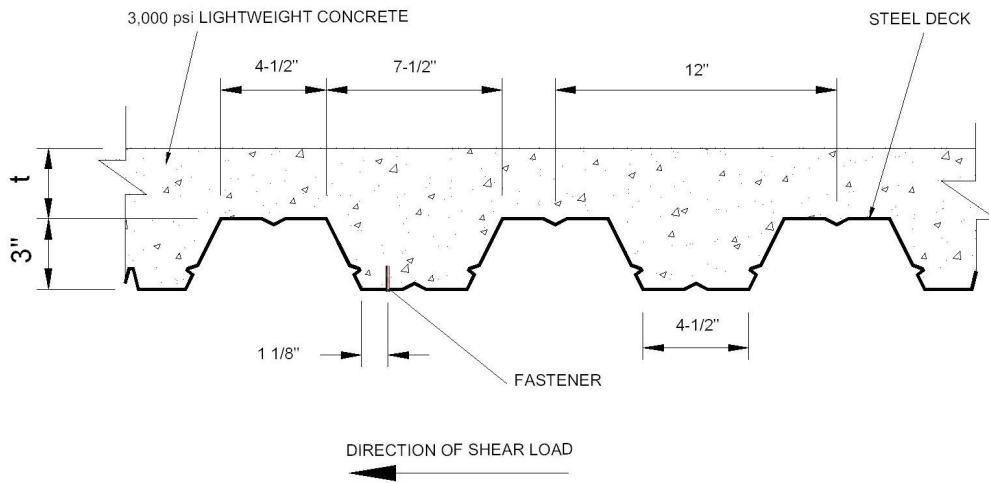

FIGURE 3—FASTENER INSTALLATION SAND-LIGHTWEIGHT CONCRETE FILLED “W3” STEEL DECK

TABLE 7—CODE SECTION NUMBER REFERENCE MATRIX

IBC			
2024 IBC	2021 IBC	2018 IBC	2015 IBC
202	202	202	202
ASCE 7-22 2.4 (IBC Section 1605.1)	ASCE 7-16/S1 2.4 (IBC Section 1605.1)	1605.3.1	1605.3.1
1605.2	1605.2	1605.3.2	1605.3.2
1901.3	1901.3	1901.3	1901.3
2201.4	2204.1 and 2204.2	2204.1 and 2204.2	2204.1 and 2204.2
AISI S100 Edition and Section Number			
2016(2020) w/S2-20 J5	2016(2020) w/S2-20 J5	2016 J5	2012 E5
2016(2020) w/S2-20 J5.2	2016(2020) w/S2-20 J5.2	2016 J5.2	2012 E5.2
2016(2020) w/S2-20 J5.2.1	2016(2020) w/S2-20 J5.2.1	2016 J5.2.1	2012 E5.2.1
2016(2020) w/S2-20 J5.2.3	2016(2020) w/S2-20 J5.2.3	2016 J5.2.3	2012 E5.2.3
2016(2020) w/S2-20 J5.3	2016(2020) w/S2-20 J5.3	2016 J5.3	2012 E5.3
2016(2020) w/S2-20 J5.3.1	2016(2020) w/S2-20 J5.3.1	2016 J5.3.1	2012 E5.3.1
2016(2020) w/S2-20 J5.3.2	2016(2020) w/S2-20 J5.3.2	2016 J5.3.2	2012 E5.3.2
2016(2020) w/S2-20 J5.3.3	2016(2020) w/S2-20 J5.3.3	2016 J5.3.3	2012 E5.3.3
2016(2020) w/S2-20 J5.3.4	2016(2020) w/S2-20 J5.3.4	2016 J5.3.4	2012 E5.3.4
2016(2020) w/S2-20 J5.3.5	2016(2020) w/S2-20 J5.3.5	2016 J5.3.5	2012 E5.3.5
Other Referenced Standards			
ASCE 7-22 Table 13.1-1	ASCE 7-16 w/S1 13.1.4	ASCE 7-16 13.1.4	ASCE 7-10 w/S1 13.1.4
TMS 402-22 8.1.4	TMS 402-16 8.1.3	TMS 402-16 8.1.3	TMS 402-13 8.1.3
IRC			
2024 IRC	2021 IRC	2018 IRC	2015 IRC
R301.1.3	R301.1.3	R301.1.3	R301.1.3
R402.2	R402.2	R402.2	R402.2

DIVISION: 03 00 00—CONCRETE

Section: 03 16 00—Concrete Anchors

DIVISION: 04 00 00—MASONRY

Section: 04 05 19.16—Masonry Anchors

DIVISION: 05 00 00—METALS

Section: 05 05 23—Metal Fastenings

DIVISION: 09 00 00—FINISHES

Section: 09 22 16.23—Fasteners

REPORT HOLDER:

ITW RAMSET

EVALUATION SUBJECT:

RAMSET T3/T4 POWER DRIVEN FASTENERS

1.0 REPORT PURPOSE AND SCOPE

Purpose:

The purpose of this evaluation report supplement is to indicate that Ramset T3/T4 Power Driven Fasteners, described in ICC-ES evaluation report [ESR-1955](#), have also been evaluated for compliance with the codes noted below as adopted by the Los Angeles Department of Building and Safety (LADBS).

Applicable code editions:

- 2023 *City of Los Angeles Building Code* ([LABC](#))
- 2023 *City of Los Angeles Residential Code* ([LARC](#))

2.0 CONCLUSIONS

The Ramset T3/T4 Power Driven Fasteners, described in Sections 2.0 through 7.0 of the evaluation report [ESR-1955](#), comply with the LABC Chapters 19, 21 and 22 and the LARC, and are subject to the conditions of use described in this supplement.

3.0 CONDITIONS OF USE

The Ramset T3/T4 Power Driven Fasteners described in this evaluation report supplement must comply with all of the following conditions:

- All applicable sections in the evaluation report [ESR-1955](#).
- The design, installation, conditions of use and identification of the Ramset T3/T4 Power Driven Fasteners are in accordance with the 2021 *International Building Code*® (IBC) provisions noted in the evaluation report [ESR-1955](#).
- The design and inspection are in accordance with additional requirements of LABC Chapters 16 and 17, as applicable.
- For seismic applications, the Ramset T3/T4 Power Driven Fasteners must comply with Section 4.1.6 of the evaluation report ESR-1955.
- Under the LARC, an engineered design in accordance with LARC Section R301.1.3 must be submitted.
- The allowable load values listed in the evaluation report and tables are for the connection of the fasteners to normal weight concrete, lightweight concrete, lightweight concrete over metal decks, concrete masonry and steel. The connection between the fasteners and the connected members must be checked for capacity (which may govern).

This supplement expires concurrently with the evaluation report, reissued August 2025 and revised December 2025.

DIVISION: 03 00 00—CONCRETE
Section: 03 16 00—Concrete Anchors

DIVISION: 04 00 00—MASONRY
Section: 04 05 19.16—Masonry Anchors

DIVISION: 05 00 00—METALS
Section: 05 05 23—Metal Fastenings

DIVISION: 09 00 00—FINISHES
Section: 09 22 16.23—Fasteners

REPORT HOLDER:

ITW RAMSET

EVALUATION SUBJECT:

RAMSET T3/T4 POWER DRIVEN FASTENERS

1.0 REPORT PURPOSE AND SCOPE

Purpose:

The purpose of this evaluation report supplement is to indicate that Ramset T3/T4 Power Driven Fasteners, described in ICC-ES evaluation report [ESR-1955](#), have also been evaluated for compliance with the codes noted below.

Applicable code editions:

- 2025 California Building Code (CBC)

For evaluation of applicable chapters adopted by the [California Office of Statewide Health Planning and Development \(OSHPD\) AKA: California Department of Health Care Access and Information \(HCAI\) and the Division of State Architects \(DSA\)](#), see Sections 2.1.1 and 2.1.2 below.

- 2025 California Residential Code (CRC)

2.0 CONCLUSIONS

2.1 CBC:

The Ramset T3/T4 Power Driven Fasteners, described in Sections 2.0 through 7.0 of the evaluation report [ESR-1955](#), comply with CBC Chapters 19, 21 and 22, provided the design and installation are in accordance with the 2024 *International Building Code*® (IBC) provisions, noted in the evaluation report and the additional requirements of CBC Chapters 16, 17, 19, 21 and 22, as applicable.

2.1.1 OSHPD:

The Ramset T3/T4 Power Driven Fasteners, described in Sections 2.0 through 7.0 of the evaluation report [ESR-1955](#), comply with CBC Chapters 19, 21 and 22 and its amendments [OSHPD 1R, 2, 3, 5 and 6], and Chapter 19A, 21A and 22A [OSHPD 1 & 4], provided the design and installation are in accordance with the 2024 *International Building Code*® (IBC) provisions noted in the evaluation report and the additional requirements in Sections 2.1.1.1 and 2.1.1.2 of this supplement, as applicable:

2.1.1.1 Verification Test Requirements: The installation verification test loads, frequency, and acceptance criteria shall be in accordance with Section 1901.3.4 [OSHPD 1R, 2 and 5] or 1910A.5 [OSHPD 1 and 4] of the 2025 CBC.

2.1.1.2 Conditions of Use: Power actuated fasteners in seismic shear applications shall be in accordance with Section 1901.3.1 [OSHPD 1R, 2 and 5] or Section 1617A.1.20 [OSHPD 1, 4 and 6].

2.1.2 DSA:

The Ramset T3/T4 Power Driven Fasteners, described in Sections 2.0 through 7.0 of the evaluation report [ESR-1955](#), comply with CBC Chapter 19, 21 and 22 and its amendments [DSA-SS/CC] and Chapter 19A, 21A and 22A [DSA-SS], provided the design and installation are in accordance with the 2024 *International Building Code*[®] (IBC) provisions noted in the evaluation report and the additional requirements in Sections 2.1.2.1 and 2.1.2.2 of this supplement, as applicable:

2.1.2.1 Verification Test Requirements: The installation verification test loads, frequency, and acceptance criteria shall be in accordance with Section 1909.2.6 [DSA-SS/CC] or 1910A.5 [DSA-SS] of the CBC, as applicable.

2.1.2.2 Conditions of Use: Power actuated fastener in seismic shear application shall be in accordance with Section 1617A.1.20 [DSA-SS].

2.2 CRC:

The Ramset T3/T4 Power Driven Fasteners, described in Sections 2.0 through 7.0 of the evaluation report [ESR-1955](#), comply with the CRC, provided the design and installation are in accordance with the 2024 *International Residential Code*[®] (IRC) provisions noted in the evaluation report.

This supplement expires concurrently with the evaluation report, reissued August 2025 and revised December 2025.